



Washing Machine Valve Test Gauge

SPECIFICATION SHEET



- Shatter proof lens mount on a 2" steel case
- 3/4" FGHT connection with a Schrader valve for input
- Easy installation rough in gauge, especially on hose bibs in washing machine outlet boxes

Part No.	Description
20200	2" 200 lb. WMOB Test Gauge, 3/4" FGHT

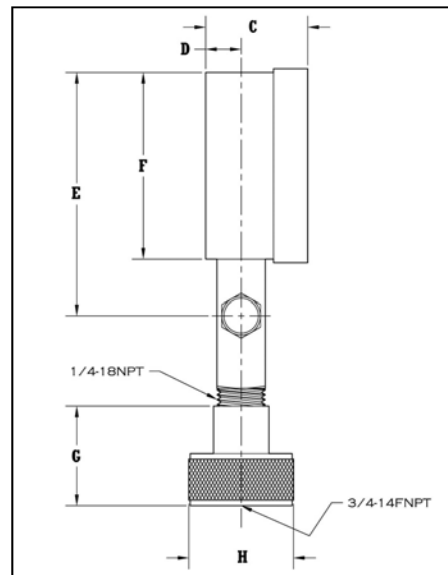
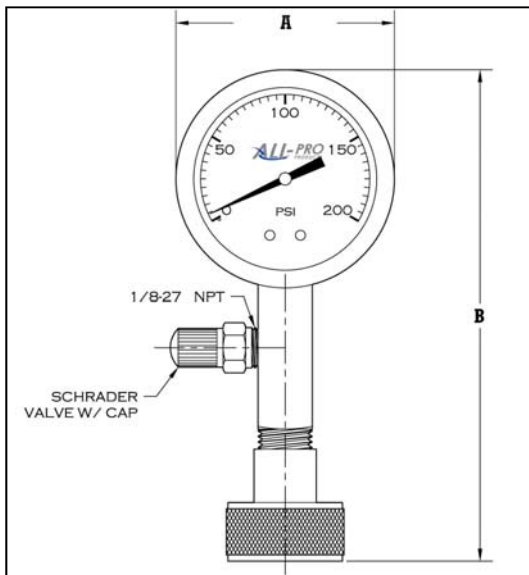

A	B	C	D	E	F	G	H
2.20" diameter	4.94"	1.15"	0.40"	2.75"	2.11"	1.13"	1.18"



Alliance Manufacturer Representatives
 1812 Durham
 P.O. Box 701085
 Houston, Texas 77270
 (800) 324-9400 / (281) 579-9400
 Fax: (800) 483-6695 / (281) 579-9849
 www.alliancereps.com

Alliance Manufacturer Representatives, inc. reserves the right to change materials or modify the Design or specifications of its products without notification as part of the company's continuing Product improvement program.

© Copyright Alliance Mfg. Representatives, Inc. 2007. All Rights Reserved. (10-07)

Job Name	Date
Part Number	Qty
Contractor	
Architect	